

BILL OF MATERIAL

MARK	QTY	DESCRIPTION	GRADE	LENGTH	WEIGHT	REMARKS
AW208	1	AWNING				
AW208	1	HSS2X1-1/2X3/16	A500-GR.B	3'-11 5/8"	14	
m217	2	HSS1-1/2X1-1/2X3/16	A500-GR.B	1'-10 1/2"	11	
m218	2	HSS1-1/2X1-1/2X3/16	A500-GR.B	2'-2 1/2"	13	
m220	1	HSS2X1-1/2X3/16	A500-GR.B	3'-11 5/8"	14	
p213	2	PL3/16"X4 15/16"		0'-5"	2	
p227	4	PL3/16"X1 1/2"		0'-2"	1	
p229	2	PL1/4"X4"		0'-4 15/16"	3	
TOTAL WEIGHT THIS DRAWING					57	

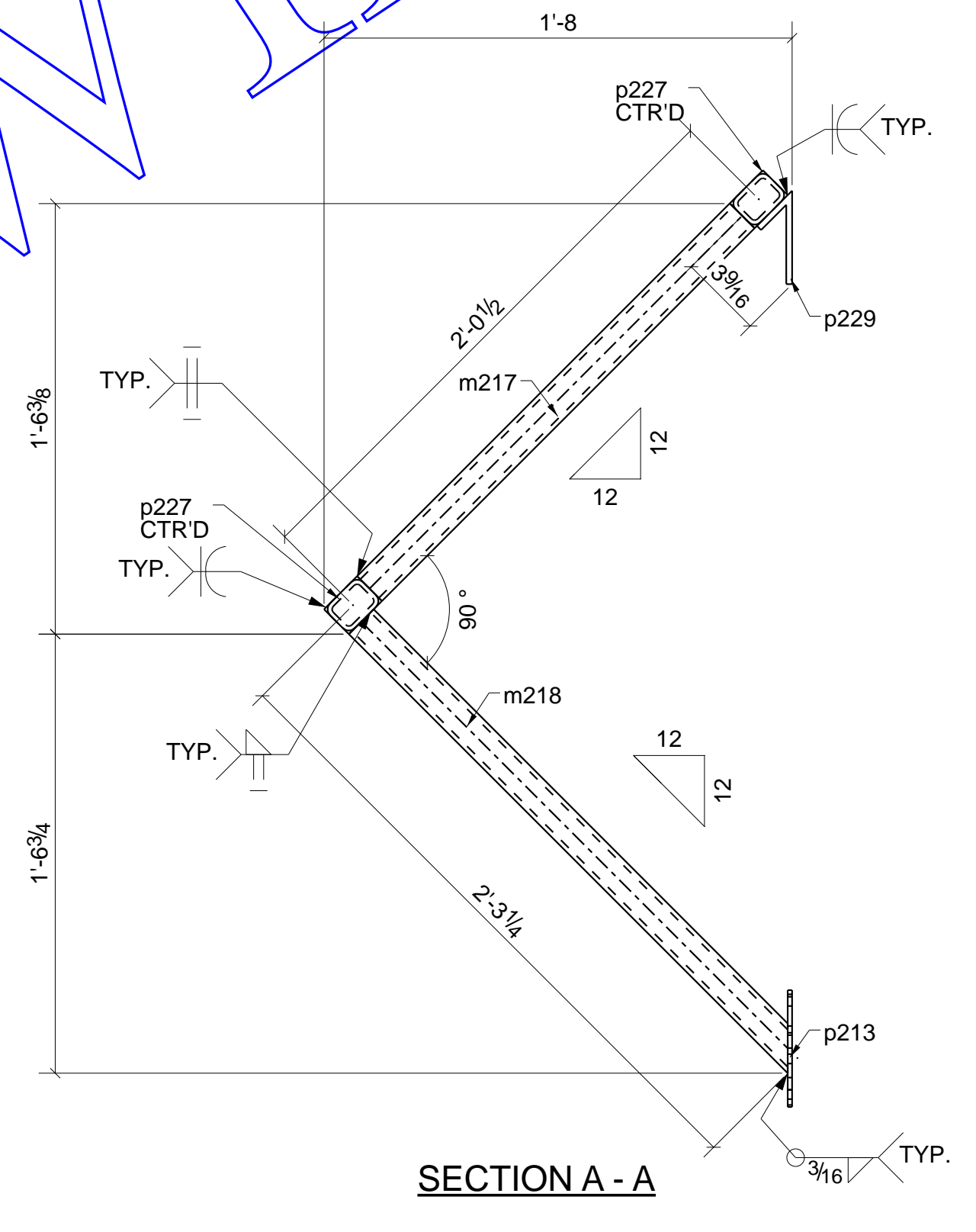
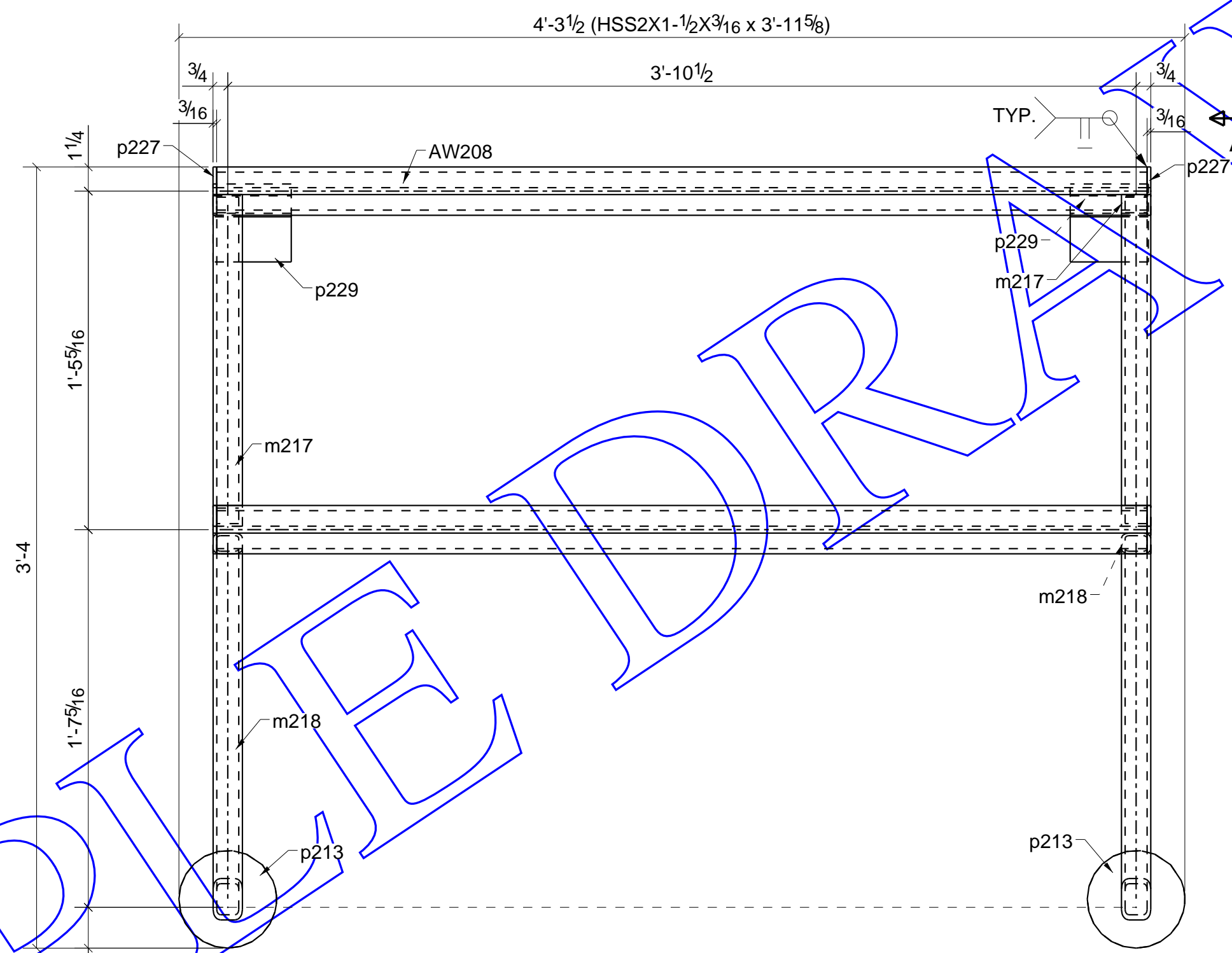
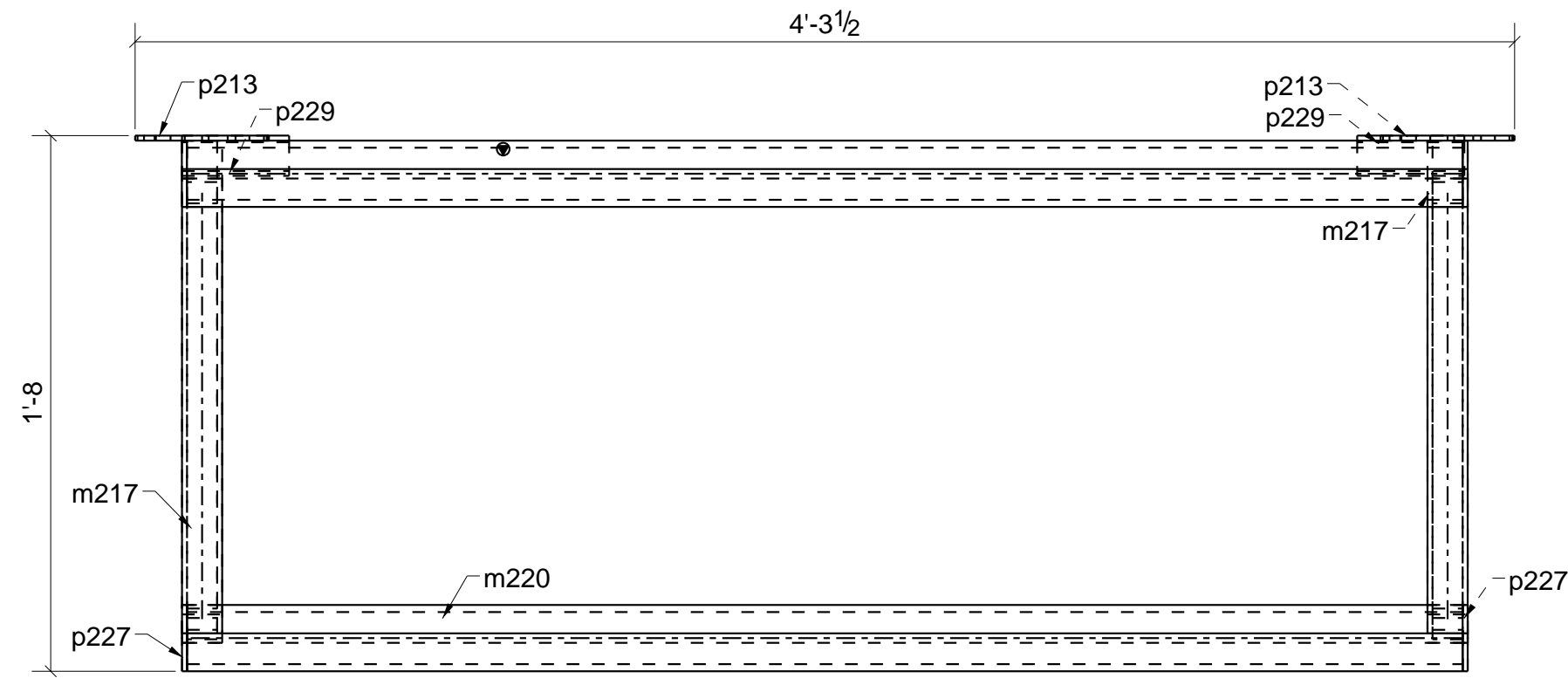

SAMPLE DRAWING ONLY

ONE - AWNING - AW208

HOLE SIZE	13/160 U.N.O.			
SHOP PAINT	RED PRIMER			
PRINT RECORD	SCALE:	JOB NUMBER:	PO NUMBER:	DRAWN BY: RSK
	DATE:	#1908		CHECKED BY: MAK
	JOB DESCRIPTION:			DRAWING NUMBER: AW208
	CUSTOMER:			
	TITLE: AWNING			

BILL OF MATERIAL

MARK	QTY	DESCRIPTION	GRADE	LENGTH	WEIGHT	REMARKS
FR101	1	FRAME				
FR101	1	TS2X2X10 GA.	A500-GR.B	6'-6 1/2"	18	
hss117	2	TS3/4X3/4X16GA.	A500-GR.B	5'-0 5/16"	6	
hss118	3	TS3/4X3/4X16GA.	A500-GR.B	0'-11"	2	
hss132	2	TS1 1/4X1 1/4X14GA.	A500-GR.B	5'-0 5/16"	10	
hss139	2	TS1 1/2X1 1/2X16GA.	A500-GR.B	0'-4"	0	
hss140	12	TS3/4X3/4X16GA.	A500-GR.B	0'-11"	6	
p138	1	PL1/4"X2"	A36	0'-2"	0	
p150	1	PL1/4"X2"	A36	0'-2"	0	
TOTAL WEIGHT THIS DRAWING					43	

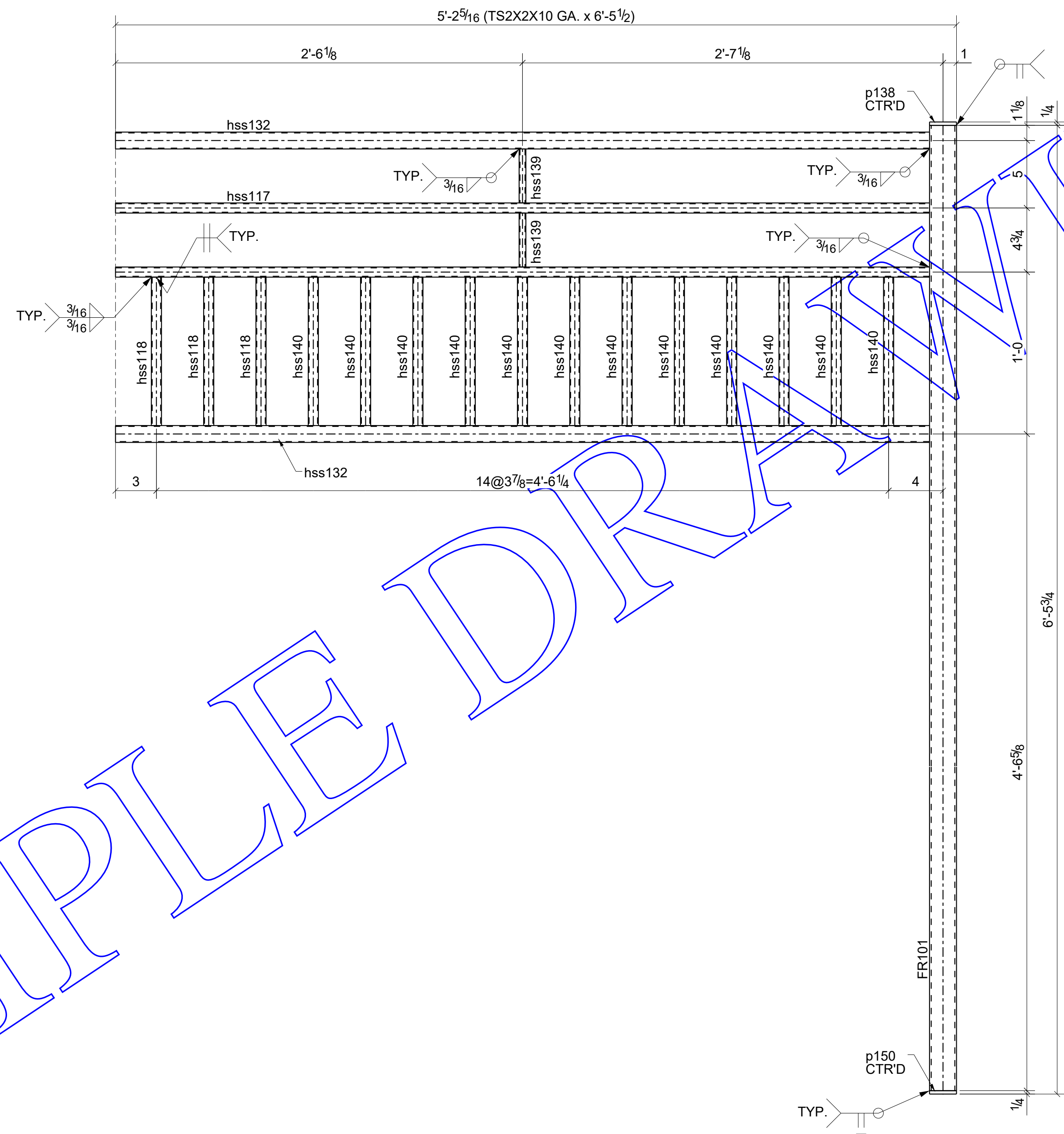

ONE - FRAME - FR101

SAMPLE DRAWING

HOLE SIZE	13/16@ U.N.O.		
SHOP PAINT	RED PRIMER		
PRINT RECORD	SCALE:	JOB NUMBER:	PO NUMBER:
	DATE:	#1908	
	JOB DESCRIPTION:		DRAWN BY: RSK
	CUSTOMER:		CHECKED BY: MAK
	TITLE:		DRAWING NUMBER: FR101
	FRAME		

BILL OF MATERIAL

MARK	QTY	DESCRIPTION	GRADE	LENGTH	WEIGHT	REMARKS
FR103	1	FRAME				
FR103	1	TS114X114X14GA	A500-GR.B	5'-0 5/16"	5	
hss112	3	TS114X114X14GA	A500-GR.B	5'-0 5/16"	15	
hss114	4	TS12X12X16GA	A500-GR.B	0'-4"	0	
hss119	4	TS34X34X16GA	A500-GR.B	5'-0 5/16"	12	
hss120	30	TS34X34X16GA	A500-GR.B	0'-11"	16	
hss122	3	TS2X2X10 GA	A500-GR.B	2'-1 7/8"	18	
p138	3	PL14"x2"	A36	0'-2"	1	
p139	3	PL14"x4"	A36	0'-4"	3	
TOTAL WEIGHT THIS DRAWING					71	

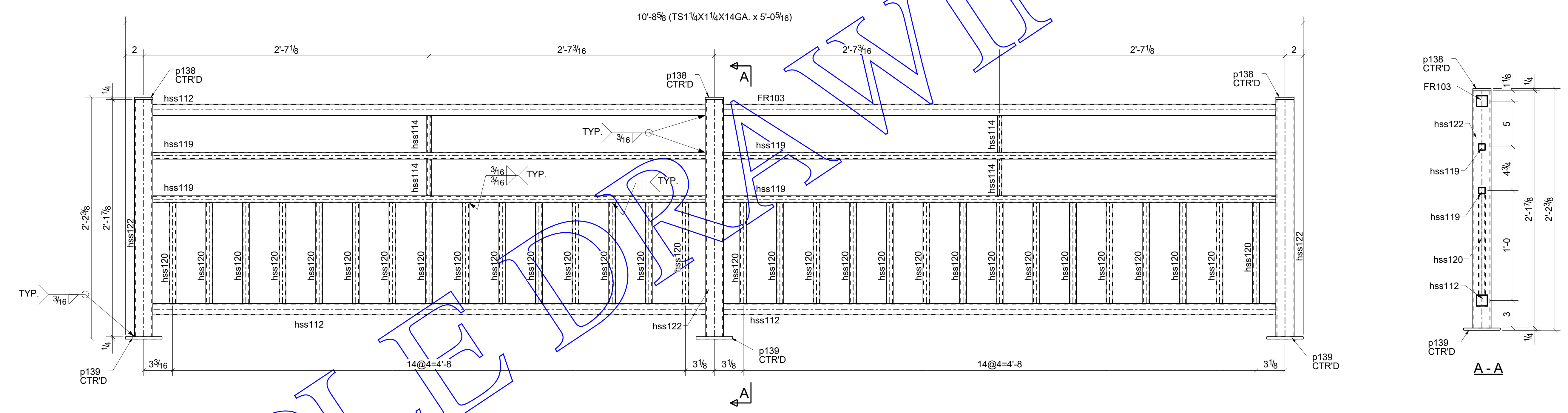

SAMPLE

ONE - FRAME - FR103

HOLE SIZE	13/160 U.N.O.			
SHOP PAINT	RED PRIMER			
PRINT RECORD	SCALE:	JOB NUMBER:	PO NUMBER:	DRAWN BY: RSK
	DATE:	#1908		CHECKED BY: MAK
	JOB DESCRIPTION:			DRAWING NUMBER: FR103
	CUSTOMER:			
	TITLE: FRAME			